

CHP Max5000

Product Overview

Converged Headend Platform



- **Accelerate deployment of new, revenue generating advanced services**
- **Innovative technology creating converged high-density platform**
- **Investment protection through 2RU footprint**
- **Simplified installation and management**
- **Universal management through Craft interface, SNMP with HMS, or remote IP access**

The CHP Max5000 converges hub, headend, and digital transport onto one scalable platform. The CHP Max5000 provides the highest density headend platform on the market, with up to 52% greater density than alternate offerings. Features include accelerated deployment of advanced services, innovative technology creating a converged high-density platform, simplified installation and management, optional redundant powering, hot-swappable modules, investment protection through its 2RU footprint, and universal management through a craft interface and SNMP.

This product overview highlights the CHP Max5000 platform components and all application modules, including the latest addition to the CHP Max5000 product line—the 1GHz CWDM 1291 and 1311 nm forward path transmitters, the first in the industry to be ITU G.695 compliant for CWDM spacing. This advanced CWDM transmitter is ideal for broadcast service providers looking to leverage their existing network infrastructure—without incurring the significant construction costs associated with additional fiber deployment—to support rapidly growing residential and business services.

Contact your C-COR sales professional for a more detailed product data sheet on our 1GHz CWDM transmitters and all CHP Max5000 application modules.

Applications

1 GHz Forward TX's (GFXV, GFXF, GFX-DXL) in Forward Segmentation Application (Unlocking Narrowcast Bandwidth)

Baseline HFC Configuration

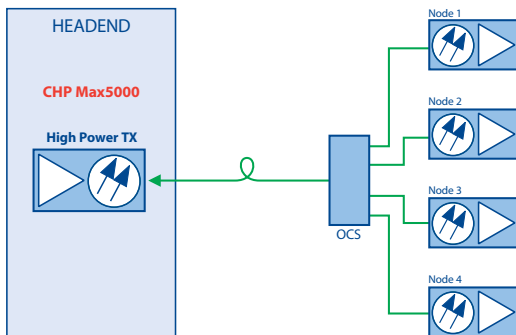

In a typical hybrid fiber coaxial network, one high power narrowcast transmitter may feed as many as four nodes, which together can serve nearly 2,000 subscribers.

Total Homes Passed: 20,000
Homes Passed/Node: 500
Nodes Required: 40
Narrowcast Group Size: 2,000 (4 nodes)
Number of Narrowcast Groups: 10
Broadcast Bandwidth: 293Mbps
Narrowcast Bandwidth: $1254 \times 10 = 12,540$ Mbps
Total Bandwidth: 12,833Mbps

Segmented Forward Path

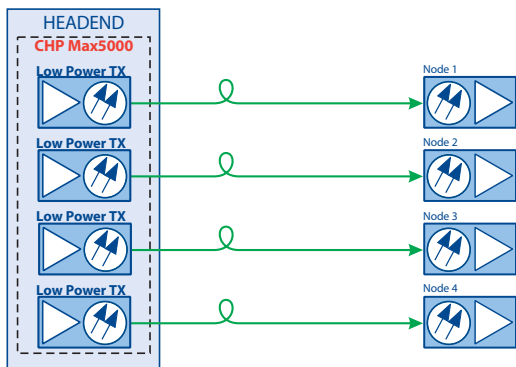

You can segment the forward path to provide more narrowcast bandwidth for advanced services by using one CHP Max5000 low power forward transmitter for each node, reducing the number of subscribers served by each transmitter to one quarter of those served before segmentation. This reduction increases bandwidth per subscriber by nearly 400%.

Total Homes Passed: 20,000
Homes Passed/Node: 500
Nodes Required: 40
Narrowcast Group Size: 500 (1 node)
Number of Narrowcast Groups: 40
Broadcast Bandwidth: 293Mbps
Narrowcast Bandwidth: $1254 \times 40 = 50,160$ Mbps
Total Bandwidth: 50,453Mbps

1 GHz CWDM Forward Transmitter

MSOs are continually pressured to increase the capacity of their HFC networks as subscribers demand HDTV, ever-increasing data download speed, business services, VoIP, and digital simulcast. The existing fiber infrastructure is rapidly becoming inadequate, if not already so, and at a cost of \$10,000/mile or more, new fiber construction may not be an option. CWDM technology is the way to go. By implementing CWDM, MSOs can combine multiple forward and return paths onto a single fiber.

The real advantage of CWDM technology can be seen in C-COR's CWDM Multi-Wavelength Access Network, which is an even more targeted solution enabling MSOs to offer the full range of next-generation residential and business services by leveraging their existing network. Rigorously tested and field-proven, this new system delivers up to 10 multiplexed 20nm spaced CWDM wavelengths of analog forward, return, and GigE services on a single fiber today with capacity for future expansion.

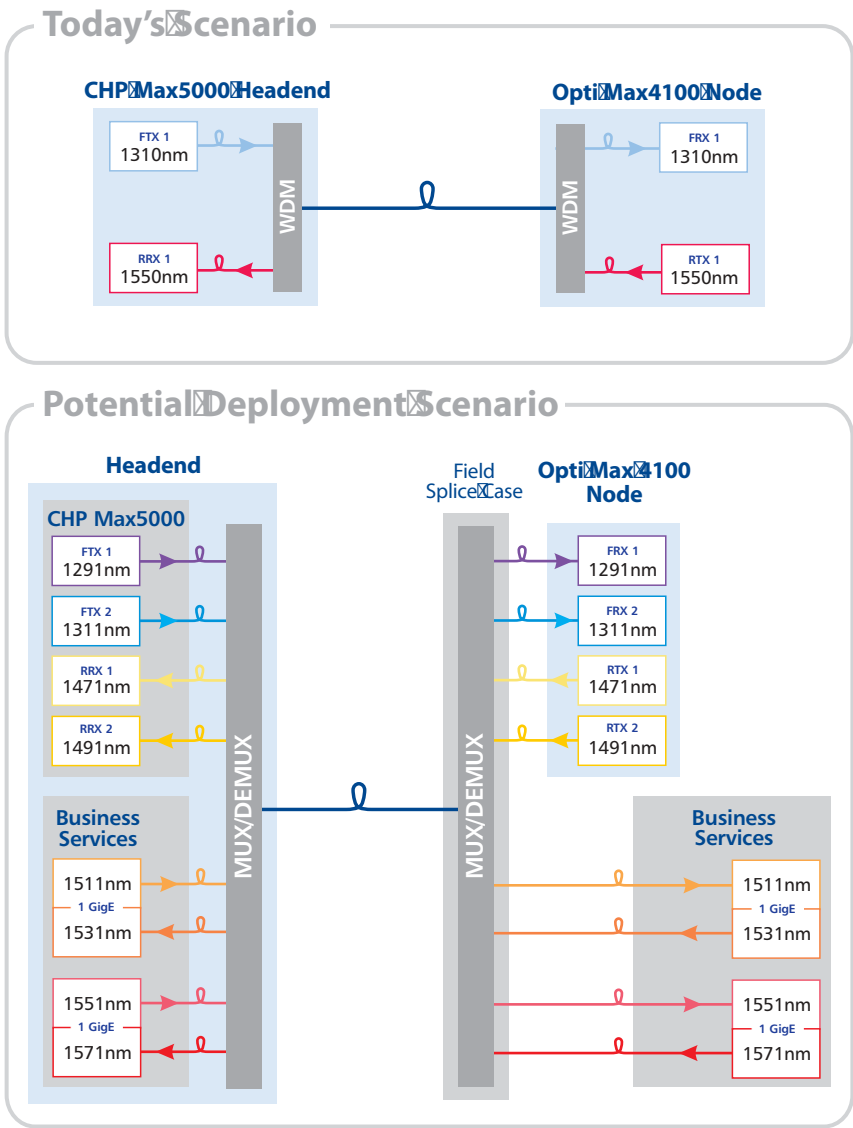

1550nm Supertrunking with XMOD TX, EDFA, GFRX

100km Single Channel Fiber Application

In the following diagram, the 79 NTSC channel output from the 1550nm XMOD transmitter is amplified by the 16dBm EDFA in the headend and then transmitted through a 45km fiber link to another 16dBm EDFA in the intermediate hub. This EDFA provides an additional gain of 16 dB for the 55 km fiber link to the forward receiver in the hub.

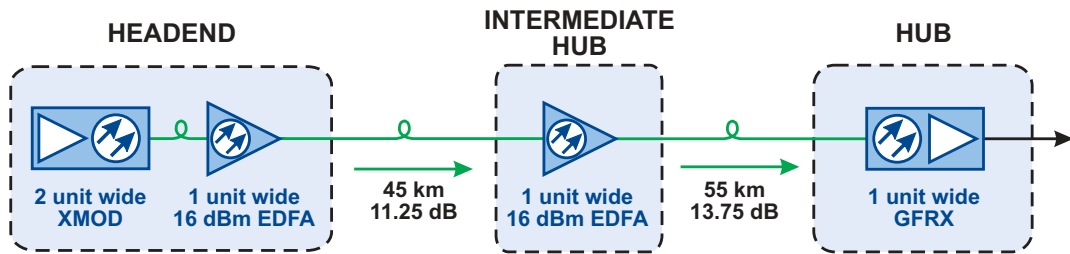

100km Split Channel/Single Fiber Application

In the following diagram, 40 NTSC channels from a 1545 nm XMOD TX and another 40 NTSC channels from a 1550nm XMOD TX are dense wave division multiplexed onto a single fiber and amplified by a 19dB EDFA in the headend and then transmitted through 45km fiber link to another 19dB EDFA in the intermediate hub. This EDFA provides an additional gain of 19dB to travel the 55km fiber link to the DWDM demultiplexer in the hub. The demultiplexer provides a 1545nm fiber optic input to a forward receiver and a 1550nm fiber optic input to the second forward receiver in the hub. The Split Channel application provides 3dB CNR, 4dB CTB and XMOD, and 5 dB CSO performance advantages over the Single Channel application.

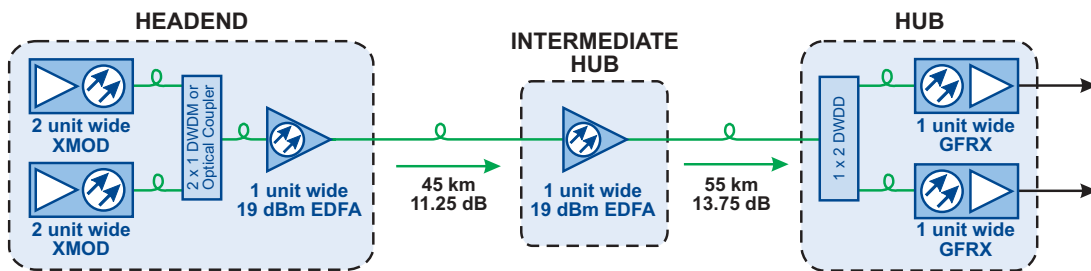

Digital Return Links with Reverse Receiver

In traditional analog return architectures, fiber optic nodes typically serve 500 homes or less. As demand for return services increases, these nodes can be modified by adding additional transmitters and segmenting return inputs. While this is definitely an advantage, the obvious disadvantages are that you need a separate fiber for each return path, and a return path receiver for each return transmitter. The cost of additional fiber and return path receivers can really add up. In addition, with the use of analog transmitters, link budgets are on the order of 10dB with maximum return optical links at 30km because of CNR limitations.

Direct Long Haul Digital Return

In this application, analog TXs and RXs are simply replaced with digital TXs and RXs. The same number of devices and the same amount of cable are required as in a traditional analog return system, but because digital transmitters and receivers are more robust—that is, less affected by noise and temperature—return optical links can be extended to as much as 100 km at 1550 nm without repeaters or optical amplifiers. Direct Long Haul Digital Return is a more cost-effective solution for extending optical links than adding EDFAs to an analog return system.

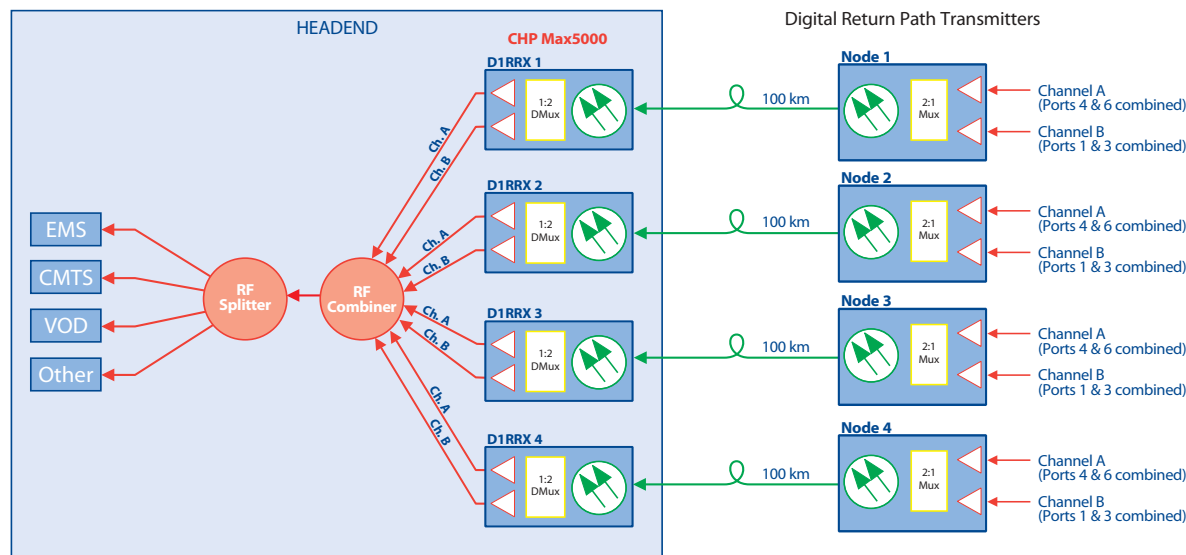

CWDM Return for Low Cost, Passive Optical Multiplexing with Limited Fiber

In this application, eight 1550nm digital return path TXs at 20nm spacing are each used for a direct short- or medium-haul return from node to hub. These eight separate return paths are then coarse wave division multiplexed onto one fiber for transport to the headend using the following wavelengths: 1471, 1491, 1511, 1531, 1551, 1571, 1591, and 1611 nm. Eight digital return receivers (CHP-D1RRX) installed in a CHP Max5000 in the headend complete this application. CWDM Digital Return is a more economical solution to DWDM on the ITU-grid and is ideal for topologies with limited fiber count.

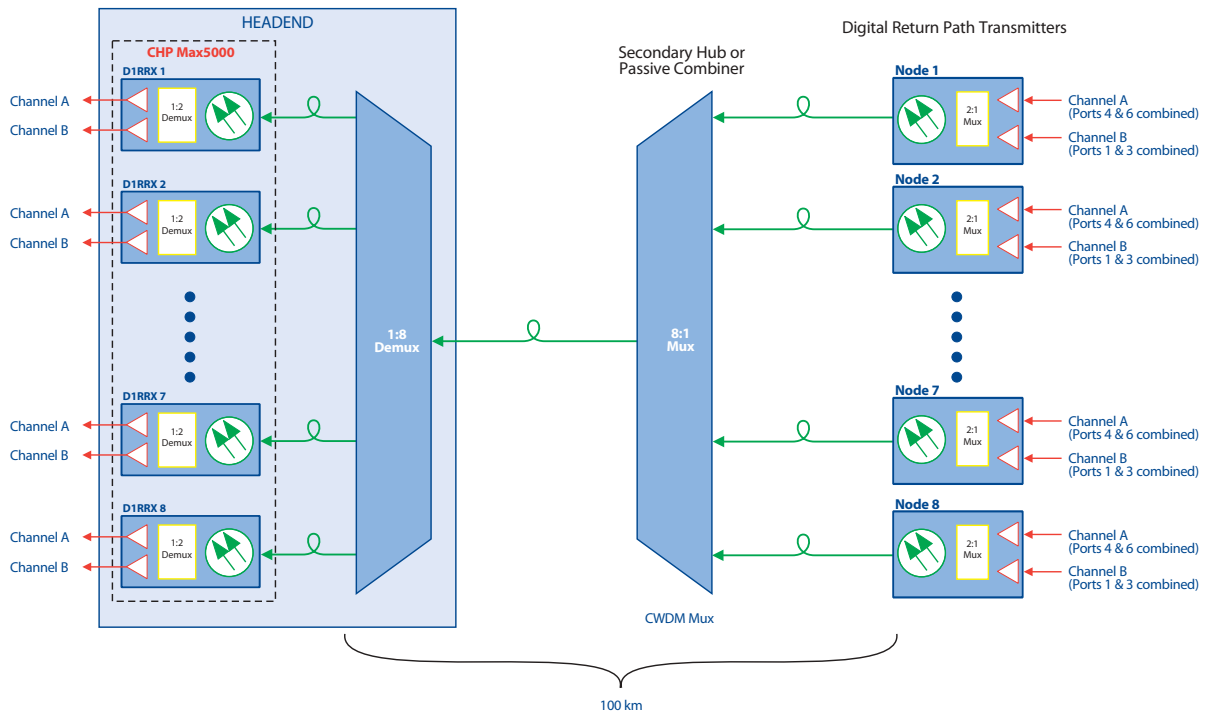

QAM overlay

In this example, narrowcast content from up to 20 QAM transmitters can be dense wave division multiplexed onto a single fiber in the headend and then transmitted up to 65km to a hub. An EDFA in the hub amplifies the optical signal, and the wavelength of the associated narrowcast transmitter is demultiplexed. The output of the demultiplexer is multiplexed with the broadcast signal of the EDFA in the hub to combine both signals onto a single fiber going to the node.

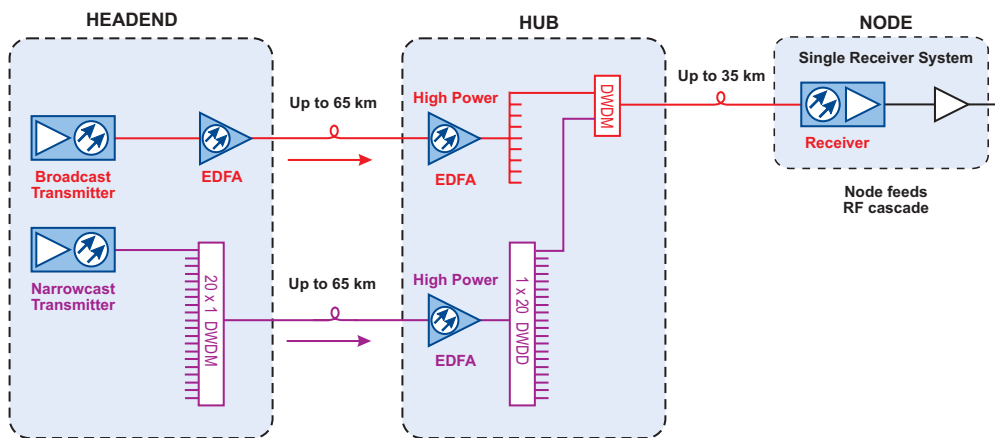

In the dual receiver architecture, the major difference from the previous example is that the broadcast and narrowcast signals are not dense wave division multiplexed onto the same fiber in the hub. Instead, the broadcast and narrowcast signals are independently routed through the headend and hub to separate receiver in the node. The RF signals are then combined in the node.

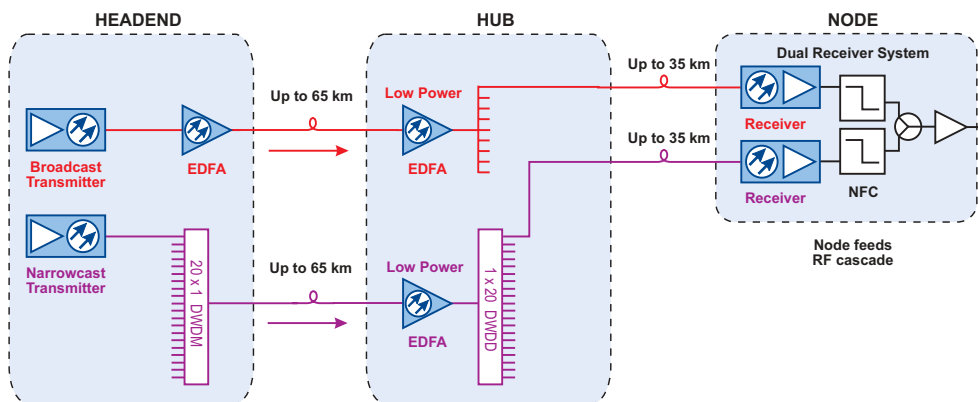

CHP Max5000 Chassis

The 2RU 19-inch CHP Max5000 chassis provides 10 module slots for application modules, 2 for isolated redundant power supplies, and 1 for a management module.

- Standard 40RU rack holds up to 200 CHP Max5000 transmitters or 400 return receivers
- Chassis available in front or rear fiber version
- Optional fiber tray and shield protect and manage fiber in the front fiber chassis
- Thermal design provides a wide operational temperature range for maximum reliability
- A plenum with eight large fans create more airflow and offer better reliability than module-based fans; in the event of a fan failure, application modules—and the services you provide—remain in operation.
- Separate interfaces built into the back panel of each chassis direct power to and convey element management information to/from installed modules.
- Universal slots accept the application modules in virtually any combination to accommodate a variety of service delivery requirements.

Rear Fiber Chassis
CHP-CHASSIS-19Q



Front Fiber Chassis
CHP-CHASSIS-R-19Q



CHP Max5000 Power Supply

CHP Max5000 isolated, load-sharing, redundant power supplies are available with either auto-sensing (110 to 220V) AC or DC (–72 to –36VDC) input. One power supply supports a completely loaded chassis, while two offer power redundancy eliminating service interruption if one power supply or line-in feed service fails.

CHP power supplies are located on the far right side of the chassis behind the Craft Management Module (CMM) or System Management Module (SMM). Isolated outputs allow the primary and redundant supplies to operate in a power-sharing configuration. Should the primary power source fail, a second power supply provides all necessary DC power. AC and DC power supplies should not be installed in the same chassis.



AC Power Supply
CHP-PS/AC1-Q

CHP Max5000 Management Modules

The CHP Max5000 management module is available in two models. The Craft Management Module (CMM) offers local monitoring and configuration along with a PC compatible graphical user interface (GUI). The System Management Module (SMM) offers all the functionality of the CMM plus remote management using SNMP with HMS-compliant MIBs for use with an external element manager or remote access to the CMM interface using an IP connection through the Ethernet interface from the remote GUI software. Both management modules offer an RS-485 interface for interconnecting multiple chassis at one site for single point control from an SMM.

The CHP Max5000 GUI simplifies system installation, provides monitoring on easy to read screens and displays all critical module information to assist in operational as well as inventory management. A complete equipment manual is also included in the Craft Management Software (CMS) bundle for access on a PC with either the Windows® NT 4.0, 2000 SP1, or XP Professional operating system.

The SMM provides remote access to the CMM interface using an IP connection through the Ethernet interface from the remote GUI software without requiring the capital expenditure of SNMP element manager. To monitor up to 10 chassis, install 1 CMM in up to 9 chassis and 1 SMM in a tenth chassis. Then, daisy-chain the chassis together and use an Ethernet connection to program, provision, monitor, and manage your CHP Max5000 equipment via an SNMP element manager. Managing more than 10 chassis is accomplished by using a 10baseT Ethernet hub or switch between the Remote Management System and the chassis containing the SMM module.



**Craft Management Module
CHP-CMM**

Craft Management Software



1 GHz Application Modules

The CHP Max5000 Advanced 1 GHz Transmitter Suite includes the 1 GHz Variable Forward Path Transmitters, 1 GHz 1311 nm CWDM Forward Path Transmitters, 1 GHz Fixed Output Forward Path Transmitter, and 1 GHz Forward Path QAM Transmitters, enabling broadband service providers to increase forward capacity for HDTV over previous program offerings, thereby allowing typically 40% increase over current HDTV channels in a lineup. CHP Max5000 1 GHz transmitters are dual-input, hot-swappable transmitters with integrated management through the local Craft GUI and remote management via SNMP HMS-compliant interface for external connection to an element manager.

C-COR's revolutionary variable optical output power range enables operators to reduce spare inventory up to 60 percent, reduce the need for optical attenuators, and account for unexpected link loss during system implementation. These benefits translate into significant CapEx and OpEx savings, and provide maximum flexibility for deploying advanced interactive services. The 1 GHz Transmitter's dual-input capability provides isolation that is much superior to alternative offerings, enabling simultaneous advanced service deployment of video and telephony without cross-talk impairments. In addition, integral high isolation eliminates having to add external devices to achieve similar performance, thereby lowering CapEx even further and reducing system complexity.

CWDM Forward Path Transmitters

The advanced 1 GHz CWDM Transmitter is ideal for MSOs that need to support a rapidly growing residential and business services on a fiber-scarce HFC plant.

- Provides the capability to multiplex two forward and multiple analog return wavelengths on a single fiber
- 1311 nm CWDM transmitter available now; 1291 and 1331 nm CWDM transmitters available soon
- 1311 ± 4 nm with variable output power levels of 4, 6, 8, or 10 dBm, output levels can be adjusted from the maximum output power to 2 dB below this level in 0.25 dB steps
- By deploying 1311 nm CWDM transmitters today, adjacent ITU channels can be reserved for future CWDM applications
- ITU G.695 standards compliant
- Variable optical output power range for spare inventory reduction and flexibility to account for unexpected link loss during system implementation
- Superior performance to facilitate 256-QAM digital channel transmission capability
- Plug-in equalizer and attenuators for RF gain control and front panel RF testpoint for convenient monitoring



**CWDM 1 GHz Forward Path TX
CHP-GFXV-1311-xx-S**

1310nm Variable Forward Path Transmitter

These 1GHz forward path transmitter are available with a maximum output power of 2, 4, 6, 8, 10, and 12dBm. The output level can be adjusted from the maximum output level to 2dB below this level in 0.25dB steps.

- Superior performance to facilitate 256-QAM digital channel transmission capability
- Plug-in attenuators for RF gain control and front-panel RF testpoint for convenient monitoring
- Dual high isolation input
- Also available in a front fiber version

1 GHz Variable Forward Path TX
CHP-GFXV-Dxx-xx-xx



1310nm Fixed Output Forward Path Transmitter

The 1GHz Forward Path Transmitter, series of fixed output rear fiber transmitters, has fixed output levels of 13, 14, and 15dBm.

- High isolation for minimum cross talk.
- Unlock narrowcast bandwidth to accelerate deployment of advanced services
- Dual RF inputs—Primary input for broadcast; Secondary input for narrowcast
- GUI configurable automatic drive control (ADC)
- Economical fixed output version of the variable output series transmitter
- Also available in a front fiber version

1 GHz Fixed Forward Path TX
CHP-GFX-D-xx-xx



Value Line 1310nm Fixed Output Forward Path Transmitter

The 1GHz Forward Path Transmitter, the value line series of fixed output rear fiber transmitters, has fixed output levels of 2, 4, 6, 8, 10, and 12dBm.

- Unlock narrowcast bandwidth to accelerate deployment of advanced services
- Dual RF inputs—Primary input for broadcast; Secondary input for narrowcast
- GUI configurable automatic drive control (ADC)
- Economical fixed output version of the variable output series transmitter

1 GHz Fixed Forward Path TX
CHP-GFXF-D-xx-S



1550nm Forward Path QAM Transmitter

The advanced 1GHz QAM Transmitters are ideally suited to transport digitally encoded video (16/64/256-QAM) and QPSK data from the headend to a hub or node.

- Accept narrowcast QAM signals, telephony, etc. from 550 to 1002 MHz and convert the RF input to an optical output at DWDM wavelengths available at odd ITU channels 21 through 61.
- Optical output power of 10dBm provides a transmitter reach of up to 150 km with an EDFA.
- Dual-input capability provides isolation that is much superior to alternative offerings, enabling the possibility to use "broadcast" QAM channels on one input, while using "narrowcast" QAM channels on the other input without cross-talk impairments. The high isolation eliminates having to add external devices to achieve similar performances, thereby lowering CapEx and reducing system complexity.
- Superior performance to facilitate 256-QAM digital channel transmission capability
- 10dBm optical output DWDM wavelengths available at odd ITU channels 21 through 61
- Plug-in attenuators for RF gain control and front-panel RF testpoint for convenient monitoring

Redundant Forward Path Receiver

C-COR CHP Max5000 1GHz Redundant Forward Receivers, designed to accept a single optical forward path signal from a CHP Forward Path Transmitter, can operate as either a stand-alone receiver with a single optical path or can be configured as a redundant receiver with the addition of a second module and a Redundant Communications Link Cable (RCL2) to maintain uninterrupted service availability in the event of optical path or hardware failure.

- Extending bandwidth from 870MHz to 1GHz increases overall forward capacity by 16% and the digital spectrum by 40%
- Automatic switchover time for optical path or hardware failure is less than or equal to 50ms.
- Offers operators the flexibility to set the optical input and RF output thresholds for switching to the redundant module and may be located in the same CHP chassis or in a different rack located within the maximum RCL2 length of 6 meters (20 feet).
- An alarm is generated if either the optical input power or RF output power exceeds a user-defined major high limit or drops below a user-defined major low limit.
- Designed for both 1310nm and 1550nm network architectures with an input power range from -10 to 4dBm.
- Provides a high RF output up to 1GHz with a noise contribution of less than 8pA/Hz^{0.5} eliminating the need for additional RF amplification when combining many circuits.
- Front-panel RF testpoint for convenient monitoring
- The front panel has module and channel status LEDs, and up and down gain adjustment buttons, which can be locked out by the local Craft Management Graphical User Interface for security purposes.
- Exceptional price/performance ratio

1 GHz Forward Path QAM TX CHP-GQTX-10-S-xx



1 GHz Redundant Forward Path RX CHP-GFRX-S



Forward Path RF Amplifier

The CHP Max5000 Advanced 1 GHz Forward Path RF Amplifier is a hot-swappable module that can be used as a key system component in a headend or hub environment to provide RF signal amplification. This amplifier is designed to allow system operators to overcome network losses, with minimal degradation to system performance, caused by combining and splitting networks that are typically found in HFC headends/hubs.

- The module has one RF input and one RF output with a passband of 50 to 1002MHz.
- Provides a gain of 22dB, superior CNR, and distortion performance.
- 22dB gain and forward passband of 50 to 1002MHz
- The amount of gain can be reduced 5 dB from the maximum output in 0.25 dB steps either locally via the Craft management software or remotely via SNMP HMS-compliant interface for external connection to an element manager.
- A front panel RF testpoint provides a sample of the RF output, reduced by 20dB for convenient monitoring
- Low profile footprint allows 10 amplifiers in a shelf

Forward Path RF Amp
CHP-GAMP



870 MHz Forward Path Transmitters

CHP Max5000 Forward Path Transmitters help MSOs unlock narrowcast bandwidth as subscribers demand advanced services and new content. By dedicating one low power transmitter to each node, CHP Max5000 helps to nearly quadruple system bandwidth capacity. CHP Max5000 transmitters are available in two versions—an economical single-input model and a full-featured, dual-input model. Both versions offer hot-swapping and integrated management through the local Craft GUI and remote management via SNMP HMS-compliant interface for external connection to an element manager.

The full featured, dual-input transmitter offers multiple levels of drive control providing maximum flexibility addressing a broad range of applications. The dual-input capability presents 60dB of isolation, much superior to alternative offerings. The dual-input forward transmitter's high performance isolation offers, for example, simultaneous advanced service deployment of video and telephony without cross-talk impairments. Integral high isolation eliminates having to add external devices to achieve similar performance, thereby lowering capital expenditures and reducing complexity.

- Unparalleled price/performance benefits
- Up to 10 transmitters per chassis and 200 transmitters per standard rack for high density and reduced operational costs
- Superior performance to facilitate 256-QAM digital channel transmission capability
- Plug-in attenuators for RF gain control
- Front-panel RF testpoint for convenient monitoring

870MHz Forward Path TX
CHP-FTX-xx-S



1550nm Externally Modulated Transmitters

CHP Max5000 Dual Output 1550nm Externally Modulated double-width Transmitters offer scalable long distance optical solutions.

- Laser options enable 1555 ± 5 nm for WDM, 1545 ± 1 nm for Red/Blue, and 1550 ITU for DWDM applications providing a variety of solutions for fiber challenged long distance applications.
- Modular system optimized for use with CHP Max5000 EDFA series modules
- Power requirements at geographical reach distances of up to 100 km—the preferred solution for HFC or FTTX applications.
- Advanced adjustable SBS from 12 to 18dB provides the flexibility to optimize link performance with minimal inventory providing both CapEx and OpEx savings.
- Advanced adjustable SBS from 12 to 18dB for maximum performance and minimal inventory

1550nm Externally Modulated TX
CHP-XMOD-xxx-xx-x



EDFA

CHP Max5000 Erbium-Doped Fiber Amplifiers (EDFAs) offer a scalable optical amplification solution. The CHP Max5000 EDFA series is designed for use with CHP Max5000 1550nm transmitters.

- Providing low noise, integrated element management capability, reduced rack space, and power requirements.
- Offered with single, dual, and triple-width modules based on the configuration option.
- Available with or without constant gain (Constant gain modules can be set for either constant gain or constant power, whereas modules without constant gain only have a constant power mode. In constant gain mode, EDFAs amplify the optical input by a fixed amount regardless of optical input power. In constant power mode, EDFAs provide a consistent optical output power regardless of optical input power.)
- Nominal output powers from 13dBm to 20dBm per port

EDFA
CHP-EDFA-xx-xx-x-x



Dual Return Path Receivers

C-COR CHP Max5000 Dual Return Path Receivers are an integral part of return path system applications and are available as either a standard or redundant module. Advanced two-way services—such as video on demand, high speed Internet access, and telephony—require superior return path delivery capacity and performance.

- High RF output and high efficiency optical performance for excellent carrier-to-noise performance
- Up to 20 separate receiver channels per chassis and 400 receivers per rack for high density and reduced cooling and power costs
- The redundant modules enable optical path and hardware protection for mission critical applications such as VoIP and business data provisioning
- Optical and RF switches will alternate between diverse paths when an optical path or module hardware fault is detected. Switch time is less than 50 milliseconds to ensure telephony call hold time.
- Module pairs can reside in the same CHP Max5000 chassis or in separate chassis up to 6 meters (20 feet) apart through interconnection with the RCL2 cable
- Redundant version integrates optical path and RF switching on same module
- Redundant pair module option can reside in same chassis or separate chassis
- 5 to 200 MHz transmission bandpass
- Front-panel RF testpoint for convenient monitoring
- RF output level adjustment per channel via front panel control, local or remote IP access to Craft GUI, or SNMP

Dual Return Path Receiver
CHP-2RRX-S (standard)
CHP-R2RR-xx (redundant)



Ordering Information

Platform Components

Component Type	Model Series	Description
Chassis	CHP-CHASSIS-19Q	Rear fiber access chassis and backplane with eight dual-speed fans for quieter operation.
	CHP-CHASSIS-R-19Q	Front fiber access chassis and backplane with eight dual-speed fans for quieter operation.
23-in External Bracket	CHP-EXTBKT-23	Bracket adapts 19-inch chassis to install in a 23-inch rack.
Power Supply	CHP-PS/AC1-Q	Isolated power supply accepting 110/220VAC input.
	CHP-PS/DC1-Q	Isolated power supply accepting -48Vdc input.
Craft Mgmt. Module	CHP-CMM	Allows local monitoring and management via laptop computer connected to the RS-232 connector on the front of the CMM.
Craft Mgmt. Software	CHP-CMS-1	Software that provides graphical user interface (GUI) and enables local communication for module setup and monitoring of a CHP Max5000 shelf from a portable computer.
System Mgmt. Module	CHP-SMM	Provides all CMM functionality and SNMP port for remote management. SMM also provides remote access to the CMM interface using an IP connection through the Ethernet interface on the back of the shelf from the remote GUI software.

Application Modules

Module Type	Model Series	Description	
Forward Transmitters	CHP-GFXV-1311-xx-S CHP-GFXV-1291-10-S CHP-GFXV-1331-10-S	1291,1311, 1331 nm CWDM dual-input, variable output 1 GHz forward TXs linearized to 550MHz. "xx" indicates max. optical output power of 4, 6, 8, 10, or 12dBm. 1291 and 1331 nm TXs are only available with a variable output level of 10dBm. SC/APC connector.	
	CHP-GFXF-D-xx-S	1310nm dual-input, fixed output 1 GHz forward "Value Line" series TXs linearized to 550MHz. "xx" indicates optical output power of 2, 4, 6, 8, 10 or 12dBm. SC/APC connector.	
	CHP-GQTX-10-S-xx	Dual-input 10dBm output 1 GHz forward QAM TX, where "xx" indicates odd ITU channel. SC/APC connector.	
	CHP-GFXV-D-xx-S CHP-GFXV-DF-xx-S	1310nm dual-input, variable output 1 GHz forward TXs linearized to 550MHz. "F" indicates a Front Fiber version. "xx" indicates max. optical output power of 4, 6, 8, 10, or 12dBm. SC/APC connector.	
	CHP-GFX-D-xx-xx CHP-GFX-DF-xx-S	1310nm dual-input, fixed output 1 GHz forward TXs linearized to 550MHz. "F" indicates a Front Fiber version. "xx" indicates optical output power. Output powers of 13, 14, and 15 dBm. SC/APC connector only available for CHP-GFX-DF-xx-S; last "xx" represent the optical connector for CHP-GFX-D-xx-xx (S=SC/APC connector, AF=FC/APC).	
	CHP-GFX-DXL-xx-S	1310nm dual-input, fixed output 1 GHz forward TXs linearized to 870MHz. "xx" indicates optical output power. Output powers of 2, 4, 6, 8, 10, 12, 13, 14, and 15dBm. SC/APC connector.	
	CHP-FTX-xx-S	1310nm single-input forward TXs linearized to 550MHz. "xx" indicates optical output power. Output powers of 2 through 15dBm. SC/APC connector.	
	CHP-FTX-D-xx-S CHP-FTX-DF-xx-S	1310nm dual-input forward TXs linearized to 550MHz. "F" indicates a Front Fiber version. "xx" indicates optical output power. Output powers of 2 through 15dBm. SC/APC connector.	
	CHP-FTX-DXL-xx-S CHP-FTX-DFXL-xx-S	1310nm dual-input forward TXs linearized to 870MHz, where "xx" indicates optical output power. "F" indicates a Front Fiber version. Output powers of 2 through 15dBm. SC/APC connector.	
	CHP-FTXV-DF-06-S	1310nm dual-input, front fiber 870MHz forward TX with variable output of 4 to 6dBm in 0.25dB steps	
	CHP-XMOD-x5-xx-x	External modulated forward TX. First "x" is wavelength; 4=1545 ± 1 nm, 5=1555 ± 5 nm. Second "x" is TX reach; M=65km, X=100km. Third "x" is channel loading; blank=80 NTSC Ch, A=112 Ch, L=40 NTSC low-band, U=40 NTSC hi-band. The last "x" represents the optical connectors (S= SC/APC, E=E2000).	
	CHP-XMOD-Dxx-M-x	External modulated forward TX with channel loading of 80 NTSC channels. "xx" is odd ITU channels from 21 to 29. "x" represents optical connectors (S=SC/APC for all models, E=E2000 for ITU Ch of 29).	
	Redundant Forward RXs	CHP-GFRX-S	1 GHz single forward redundant RX accepting 1200 to 1620nm with an input level from -10 to 4dBm. SC/APC connector.
		CHP-RFRX-S	870MHz single forward redundant RX accepting 1200 to 1620nm with an input level from -10 to 4dBm. SC/APC connector.
	Return Transmitters	CHP-RTX3-10-S	1310nm dual-input return TX. 10dBm output. SC/APC connector.
CHP-RTX5-10-S-xx		1550nm dual-input return TX. 10dBm output. "xx" indicates odd numbered ITU channel (21 through 49). SC/APC connector.	
Return Receivers	CHP-2RRX-S	Dual return RX accepting 1200nm to 1620nm optical input. SC/APC connectors.	
	CHP-R2RR-xx	Redundant dual return RX accepting 1200 to 1620nm optical input. "xx" represents optical connectors (S=SC/APC, UF=FC/UPC).	
	CHP-D1RRX-S	Redundant 1:2 TDM return RX accepting 1465 to 1615nm optical input. S=SC/APC connector.	
	CHP-1RRX-S	Single front fiber access return RX accepting 1200nm to 1620nm optical input. S=SC/APC connector.	
	CHP-R2RRFF-S	Redundant front fiber access dual return RX accepting 1200 to 1620nm optical input. S=SC/APC connectors.	
EDFAs	CHP-EDFA-CG-xx-1-S	EDFA with constant gain or constant power operating modes. Available with output power of 13, 16, 19, or 22dBm with 1 port. S=SC/APC connector.	
	CHP-EDFA-xx-x-x	EDFA with constant power operating mode. "xx" represents output power of 16dBm (4 or 8 ports), 19dBm (2, 4, or 8 ports), 20dBm (8 or 16 ports), or 21 dBm (2 or 4 ports). Next "x" indicates number of ports. Last "x" represents optical connectors; S=SC/APC (2 or 4 ports), L=L (4 or 8 ports).	
RF Amplifiers	CHP-GAMP	1 GHz forward path RF amplifier.	

Contact your C-COR sales professional for data sheets on CHP application modules.

Americas Headquarters

60 Decibel Road • State College • Pennsylvania • 16801 • USA
 T: 1-814-238-2461 T: 1-800-233-2267 F: 1-814-238-4065

EuroPacific Headquarters

Transistorstraat 44-V • 1322 CG Almere • The Netherlands
 T: 31-36-546 1111 F: 31-36-536 4255

CHP Max is a trademark and the C-COR logo is a registered trademark of C-COR Incorporated.
 Copyright © 2006 C-COR Incorporated. All rights reserved.



www.c-cor.com

