

Flex Max500

Cabinet Trunk/Bridger Amplifiers

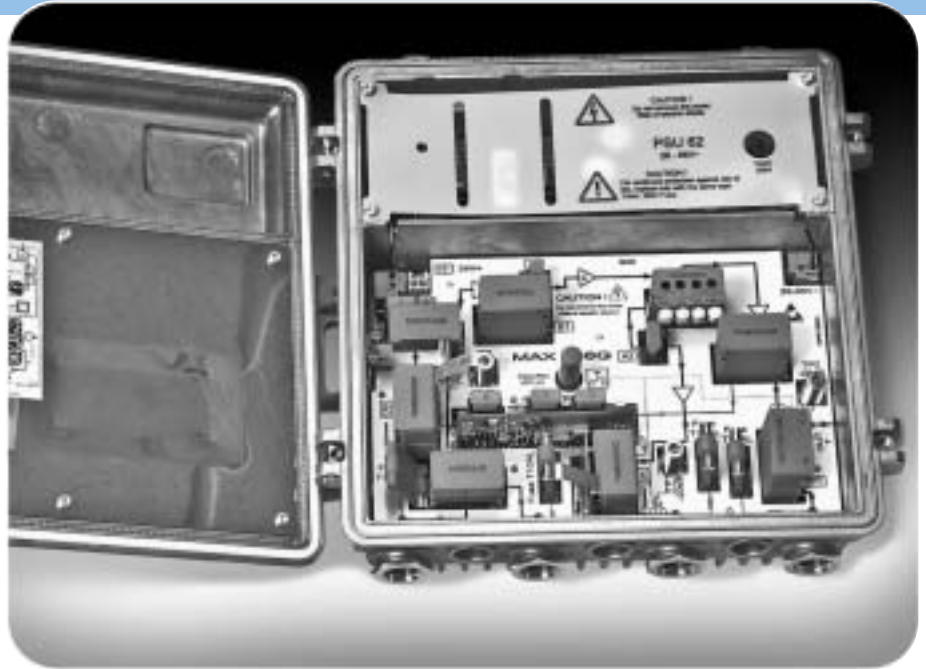

- **HFC applications with a high number of cascaded amplifiers**
- **Trunk amplifier with high performance outputs**
- **GaAs technology for improved system performance**
- **Powerful distribution amplifier**
- **Two or three high level RF outputs**
- **Plug-in diplex filters allow future upgrades**
- **Swappable power supply decreases service and maintenance costs**

The C-COR Flex Max500 Cabinet Trunk/Bridger Amplifier provides signal amplification with two or three high performance RF outputs and a maximum gain of 2 x 36dB. Combined with installer friendly features built in, you can cost-effectively deploy a multimedia platform.

High modularity ensures that the Flex Max500 Cabinet Trunk/Bridger Amplifier is future-proof and enables the operator to use this amplifier in various HFC applications.

By inserting the appropriate plug-in modules, the Flex Max500 can be used as a:

- Mini trunk/bridger amplifier (with control module)
- High performance distribution amplifier

Applied robust GaAs technology improves system performance and drives total system cost down and results in less power consumption. Sets of different plug-in diplex filters allow return bandwidth upgrade, and return channel plug-ins are available to provide either an active or a passive return path. The return path modules are frequency-compensated and enable the use of the total bandwidth. All ports are surge protected.

Features

- Optional control module, CM862/xx, provides extremely flat frequency response with correction in four frequency ranges allowing for long cascades and minimal performance degradation
- Modular design and high flexibility enable an upgrade path for future services, without a high initial investment
- Electronic testpoint at the input for negligible insertion loss and improved CNR

Flex Max500 Cabinet Trunk/Bridger Amplifiers

- Switchable forward and return directional testpoint for easy and accurate system alignment
- Optional housing sealing provides enhanced watertightness for aerial applications and manhole installations per IP67 protection standards
- Surge arrestors at all ports for increased system reliability
- Excellent low noise figure due to new GaAs preamplifier
- Transponder module available to integrate in EMS system located at the headend for improved system reliability, including gate level control options

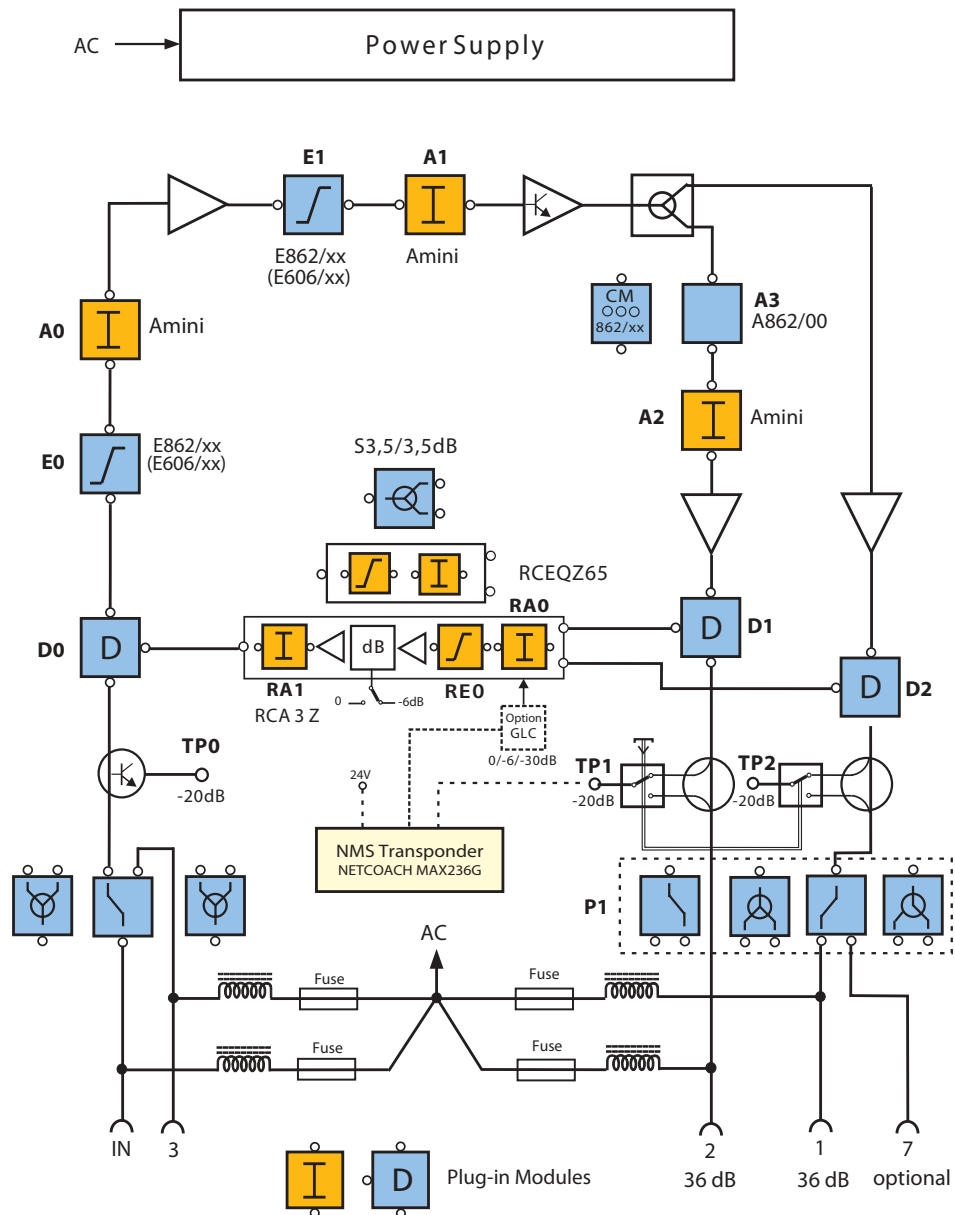

Flex Max500 Cabinet Trunk/Bridger Amplifier Block Diagram

Specifications

General Specifications

Band Coverage	47/54/70/85 to 862 MHz
Frequency Response	± 0.75 dB
Noise Figure (Note 1)	6 dB, at full gain
Return Loss (Note 1)	> 18 dB at 47 MHz (–1.5 dB/octave up to 862 MHz)
Gain (Note 1)	2 x 36 ± 1 dB 28 dB with CM862 (output 2)
Impedance	75 Ohm
Testpoints (input and output)	–20 dB
Power Consumption, including supply efficiency	< 29 W, with return amplifier

Power Passing Capabilities

RF Ports	7 A, max.
Local Power Input	8 A, max.

Performance Specifications (Note 2)

Output Level for 62 dB CTB Performance	110 dB μ V (50 dBmV)
Output Level for 65 dB CSO Performance	110 dB μ V (50 dBmV)

Active Return Channel Amplifier RCA3Z/xx

Band Coverage	5 to 30/42/55/65 MHz, frequency compensated. Attenuator and equalizers with Amini PADs.
Module Gain (Note 3)	25 dB
Station Gain, with diplex filter and splitter	19 dB, at full gain
Output Level (IM2 > 60 dB)	110 dB μ V (50 dBmV)

Passive Return Channel Modules

RCEQ Z 65	Return channel equalizer, frequency compensated. Attenuator and equalizer with Amini PADs. 8 dB insertion loss from output to input.
-----------	--

Physical and Environmental Specifications

Dimensions (W x H x D)	230 x 99 x 223 mm (9.1 x 3.9 x 8.8 in.)
Weight, approx.	4 kg
Temperature Range	–20 to 60°C (–4 to 140°F)
Protection According to IEC 529	IP55, optional IP67

Reliability

MTBF	> 50 years
------	------------

Plug-in Modules

Return Channel Amplifier 25 dB gain	RCA3Z 25/30 MHz, RCA3Z 25/42 MHz, RCA3Z 25/55 MHz, RCA3Z 25/65 MHz
Diplex Filters	D30/47 MHz, D42/54 MHz, D55/70 MHz, D65/85 MHz
Control Module CM862	CM862/00 MHz, CM862/47 MHz, CM862/54 MHz, CM862/85 MHz
Attenuators	Amini/xx PADs, xx=0 to 20 dB in 1 dB steps A862/00 bridger; A862/xx, xx=2,4,6,8, or 10 dB
Equalizers	E862/xx, xx=2,4,6,8,10,12,14,16 dB E606/xx, xx=2,4,6,8,10,12,14,16,18, 20 dB
Splitter	S3.5/3.5 dB
Directional Couplers	TAP 8/1.5 dB, TAP 10/0.5 dB, TAP 16/0.5 dB
Cable Equivalence	CE862/2,4,6,8 dB
Return Channel, passive	RCEQ Z 65

Notes:

1. Including diplex filters and 0 dB PADs.
2. According to EN50083-3, 42 CENELEC channel loading, and with diplexer modules and 8 dB slope.
3. An on-board jumper can reduce gain by 6 dB.

Specifications subject to change without notice

Ordering Information

									1	2	3	4	5	6	7
M	A	X	2	3	6	G	-	x	0	x	x	x	x	x	x

1 Power Supply	
0 Remote powering, Europe (28–65VAC)	a
1 Local powering, Europe (230VAC)	
3 Remote powering, USA (40–90VAC)	
a) Select "2" in #3 block, Fuse .	

2 RF Testpoint Connector	
0 F-type, female	

3 RF Adapter	
0 IEC-type	
1 3.5/12	
2 F-type	
3 PG11 to 5/8-inch reduction ring	
4 No adapter: PG11 entry	
5 Customized RF adapter	

4 Fuse	
0 Standard fuse 10A	a
1 Short circuit	
2 No fuse (in case of local powering)	
a Select "1" in #1 block, Power Supply .	

5–6 Status Monitoring Module	
00 No transponder	
1x NET COACH MAX236G-AM	
2x NET COACH MAX236G-HMS	

Element Management Frequencies (please specify)	
x = Group (Forward/Return Frequency)	
A	108.50MHz/6.50MHz
B	115.25MHz/9.75MHz
C	115.25MHz/18.00MHz
D	75.00MHz/8.00MHz
E	108.50MHz/15.00MHz
F	108.50MHz/5.50MHz
G	93.00MHz/10.00MHz
Other frequencies available on request.	
Frequency range: Forward 48–120MHz; Return 5–42MHz.	

7 Protection	
0 IP55	
1 IP67	

Americas Headquarters

60 Decibel Road • State College • Pennsylvania • 16801 • USA
 T: 1-814-238-2461 T: 1-800-233-2267 F: 1-814-238-4065

EuroPacific Headquarters

Transistorstraat 44-V • 1322 CG Almere • The Netherlands
 T: 31-36-546 1111 F: 31-36-536 4255

Flex Max is a trademark and the C-COR logo is a registered trademark of C-COR Incorporated.
 Copyright © 2006 C-COR Incorporated. All rights reserved.



www.c-cor.com