

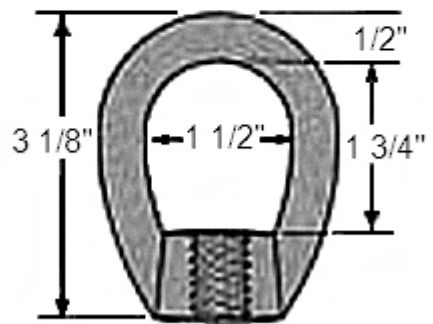

THIMBLE EYENUT
FIG. 3



OVAL EYENUT
FIG. 1



Features:

- Eyenuts are tapped to fit hot dip galvanized bolts made to ANSI Specifications and are designed to develop strength ratings consistent with the bolts with which they are used.
- Thimble eyenuts are used for span, head and stub guying; twin eyenuts accommodate double guys.
- Oval eyenuts are used for deadending with suspension or strain insulators.

Materials:

- Hot Dip Galvanized

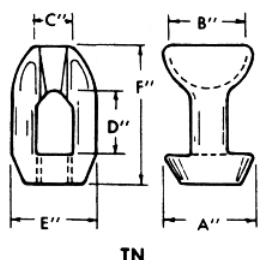
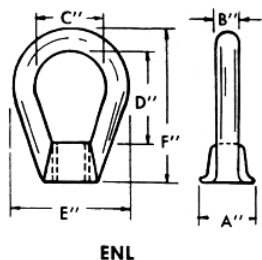
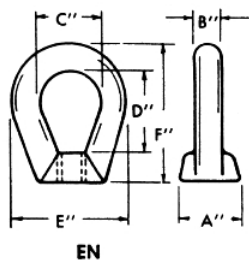

Catalog Number	Catalog Number (2)	Fig.	A	B	C	D	E	F	Weight/100 (lbs)	Bolt Size (Inches)
EN-3		1	1-3/8	9/16	1-1/2	1-3/4	2-5/8	3		3/8
EN-4		1	1-3/8	9/16	1-1/2	1-3/4	2-5/8	3		1/2
EN-5	J1092	1	1-3/8	9/16	1-1/2	1-3/4	2-5/8	3		5/8
J1093	EN-6	1	1-3/8	9/16	1-1/2	1-3/4	2-5/8	3		3/4
ENL-5		2	1-3/8	5/8	1-1/2	2-1/2	2-5/8	4		5/8
ENL-6		2	1-3/8	5/8	1-1/2	2-1/2	2-5/8	4		3/4
TN-5	J6510	3	1-1/2	1-1/2	7/8	1-3/8	1-7/8	3		5/8
J6511	TN-6	3	1-1/2	1-1/2	7/8	1-3/8	1-7/8	3		3/4
J16512	D6512	3	2	2	7/8	1-1/2	2	4-1/2	200	1



TWIN EYENUT

Twin EyenuTs			
Catalog Number	Bolt Diameter (Inches)	Strand Size (inches)	Weight/100 (lbs)
J6515	5/8	5/8	177
J6516	3/4	5/8	176

www.macleancleanpower.com